

TOP VIEW

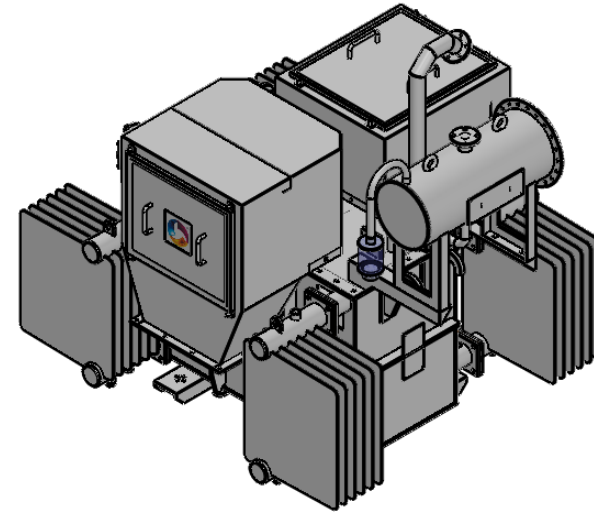

ELEVATION VIEW

| 500 KVA OFFLOAD TRANSFORMER | |
|-----------------------------|----------------|
| OVERALL DIMENSION | |
| LENGTH | 2050 (6.72 FT) |
| WIDTH | 1750 (5.74 FT) |
| HEIGHT | 1800 (5.90 FT) |

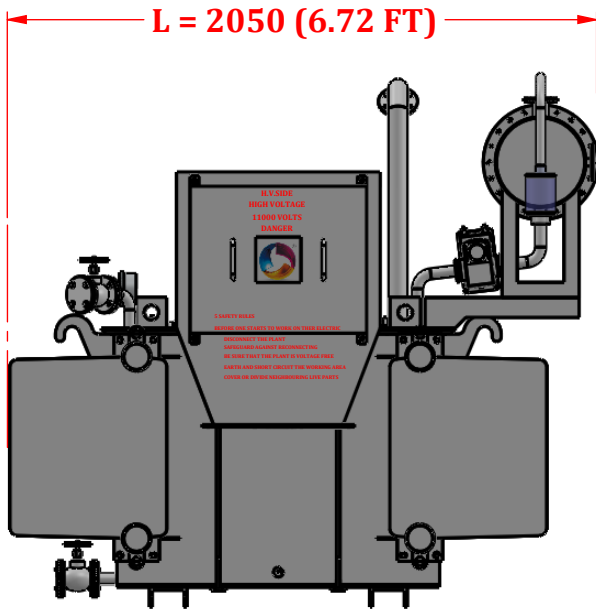

FRONT VIEW

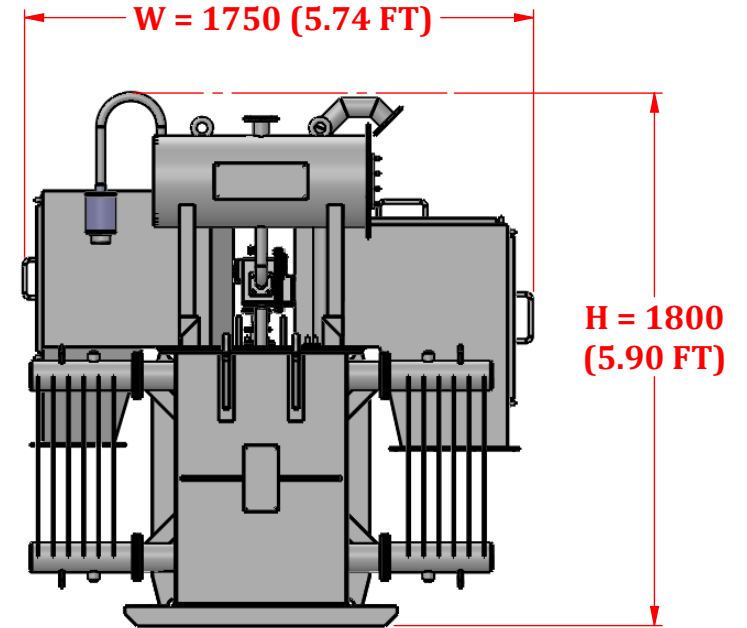

R.H. SIDE VIEW